

THE

General Radio EXPERIMENTER

VOLUME XV No. 11

MAY, 1941

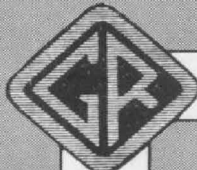

ELECTRICAL MEASUREMENTS AND THEIR INDUSTRIAL APPLICATIONS

Also

IN THIS ISSUE

Page

THE GENERAL RADIO
STANDARDIZING
LABORATORY..... 6

RADIO-FREQUENCY CHARACTERISTICS OF THE TYPE 726-A VACUUM- TUBE VOLTMETER

● BECAUSE OF THE WIDE AC-
CEPTANCE of the TYPE 726-A Vacuum-
Tube Voltmeter¹ for the measurement of

voltage and current² at radio frequencies, a discussion of its behavior at frequencies up to 150 megacycles may be of some general interest.

A knowledge of the effective input impedance at the terminals of a voltmeter is desirable so that the instrument can be used with confidence in a given application. With an exact knowledge of the input impedance and its variation with frequency, it will, in general, be possible to estimate or compute the effect of the voltmeter on the circuit under measurement.

In most applications, however, one component only of the impedance is of real significance. For example, when measuring the voltage across tuned circuits it is usually possible to retune the circuit

FIGURE 1. Panel view of the TYPE 726-A Vacuum-Tube Voltmeter.

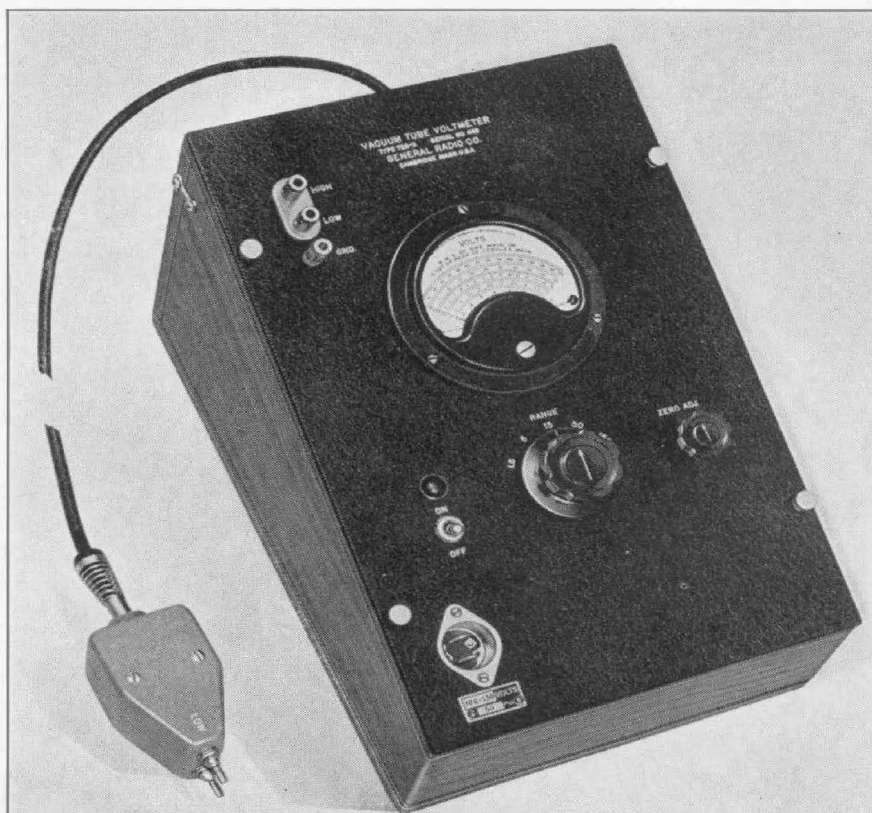

to compensate for the capacitance, so that the parallel resistance R_p becomes the effective input impedance. When making measurements on untuned circuits, on the other hand, the capacitance is the significant component, its impedance being much smaller than R_p at high frequencies.

When the voltmeter is used as an indicator in the parallel-resonance method of impedance measurement, both components of impedance are absorbed by virtue of the substitution method employed. In this case, however, the finite impedance of the vacuum-tube voltmeter acts to reduce the "resolving power" of the method of measurement. Thus, even here, a knowledge of the impedance is useful, as it permits us to estimate the resulting limitations on range and accuracy.

Figure 2 shows the measured variation

of the effective parallel resistance R_p , as well as the parallel capacitive reactance X_p of the TYPE 726-A Vacuum-Tube Voltmeter. The new TYPE 821-A Twin-T Impedance-Measuring Circuit⁸ was used in making these measurements over the frequency range from 1 megacycle to 30 megacycles. At the lower frequencies the TYPE 516-C Radio-Frequency Bridge was used, while in the region from 30 to 100 megacycles a susceptance-variation circuit⁹ was employed. The measurements were made on several voltmeter probes, with the plug tips removed. At low frequencies the input impedance is equivalent to a resistance of approximately 6 megohms, shunted by a capacitance of $6.6 \mu\mu\text{f}$. The reduction in R_p at the higher frequencies is caused by dielectric losses. These losses occur in the yellow bakelite housing between the input terminals, in the ceramic tube socket, in the blocking condenser and the resistors,

FIGURE 2. Plots of input reactance, resistance, and dissipation factor of TYPE 726-A Vacuum-Tube Voltmeter as a function of frequency.

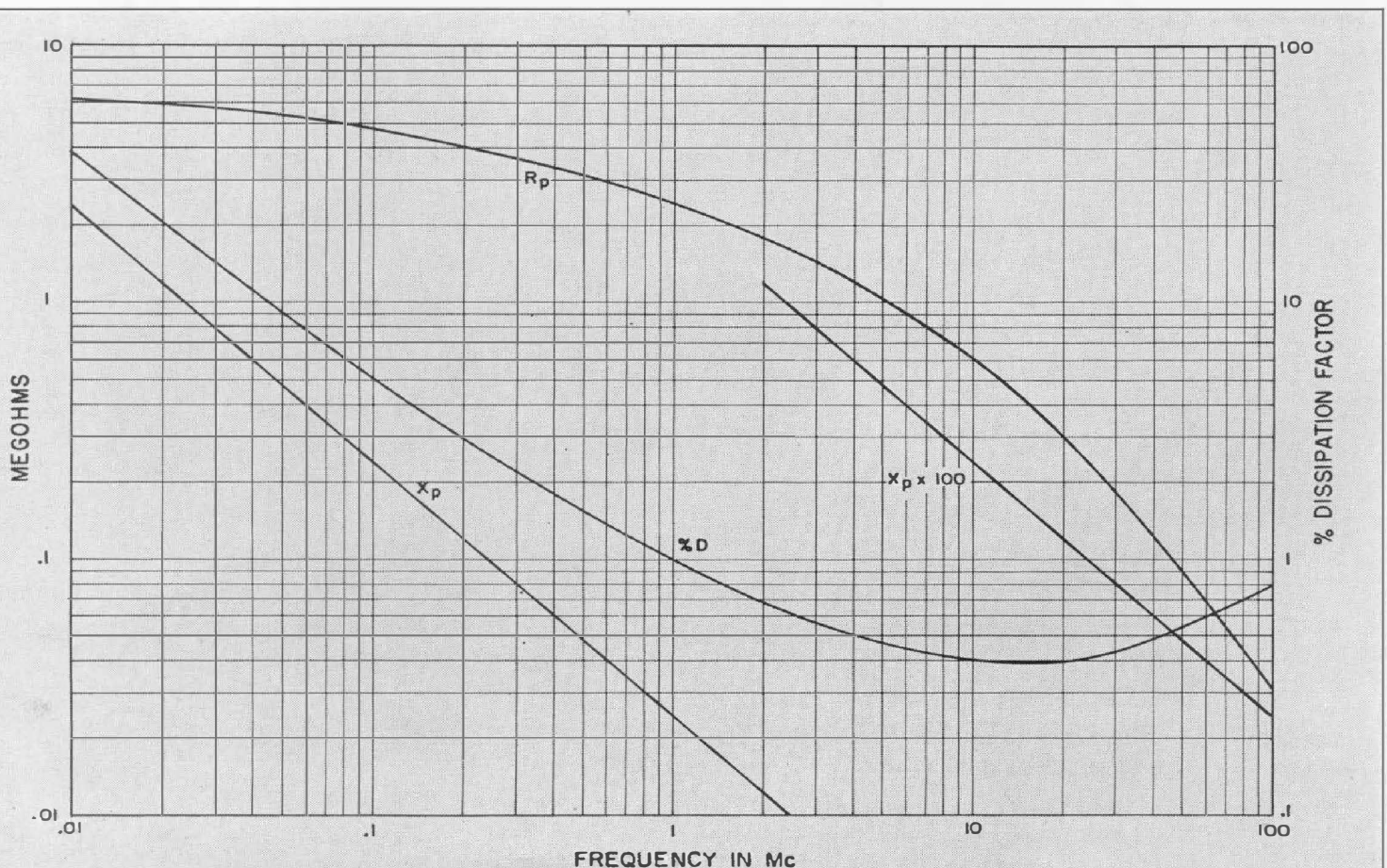

and in the glass envelope of the diode. (The diode conductance loss is unimportant at high frequencies.) The total input impedance may also be considered as that of a capacitance whose dissipation factor varies with frequency. The effective dissipation factor $\frac{1}{R_p \omega C}$ of the input capacitance is also plotted in Figure 2.

When the TYPE 726-P1 Multiplier³ is used with the vacuum-tube voltmeter the effective input impedance is even higher than that indicated by Figure 2, being approximately equivalent to that of a 4.5 μmf condenser of less than 0.5% power factor. The multiplier thus is an excellent means of obtaining extremely high input impedances, if the 10:1 reduction of sensitivity is permissible.

It is well known that certain frequency effects are present in any vacuum-tube voltmeter circuit, which cause the voltage indications at very low and at very high frequencies to differ from the true value of the applied voltage. At some low frequency the reactance of the condenser in the diode rectifier circuit will become sufficiently high so that a significant fraction of the applied voltage appears across it rather than across the diode. In addition, the dynamic characteristics of the indicating meter and the characteristics of the amplifier can also become important in determining the response to the impressed voltage. In the TYPE 726-A Vacuum-Tube Voltmeter, however, these other effects become significant at frequencies much lower than those at which the reactance error first becomes appreciable. The performance is substantially independent of frequency, even at the lowest audio frequencies. At 20 cycles the error is less than 1%.

At high radio frequencies, on the other hand, two important phenomena come

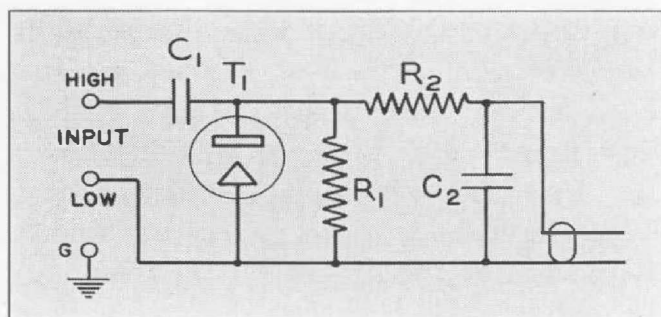

FIGURE 3. Schematic diagram of the input circuit of TYPE 726-A Vacuum-Tube Voltmeter.

into play that have a progressively more important effect on the performance of the voltmeter as the frequency is raised. The most commonly known of these is resonance in the input circuit of the voltmeter. To a first approximation, it can be considered that the inductance of the input leads resonates simply with the anode-to-cathode capacitance of the diode, causing the voltage acting on the diode to increase. As a consequence, the voltmeter reads higher than the true value of the impressed voltage. The resulting increase in voltmeter indication can be calculated with a fair degree of accuracy for frequencies up to one-half or one-third of the resonant frequency,* and the result is independent of the voltage level.

The second important phenomenon which affects the behavior of a voltmeter at high frequencies is the finite time of transit of electrons from the cathode to anode of the diode rectifier. This effect has been widely discussed in the literature^{4,5,6} under the various names of "electron-inertia error," "transit-time effect," and "premature cut-off."

Referring to Figure 3, the condenser C_1 tends to charge to the voltage required to turn back electrons at the anode of the diode.⁷ If the time of elec-

*The resonant frequency is approximately 400 megacycles, with the probe tips removed.

tron flight in the diode is negligible compared to the period of the alternating voltage, the condenser voltage will be very nearly equal to the peak value of the impressed voltage. Actually, however, the transit time is comparable to the period at the higher frequencies, and the electric field acting on an electron changes while it is in flight. The retarding field acting during the inverse portion of the cycle effectively reduces the voltage required to turn the electron back. Consequently, the voltage on *C* will not reach the value that would occur for a negligible transit time. It can be seen that the effect of this phenomenon is a voltage indication that is lower than the true value. Furthermore, since the time of transit is a function of the plate-to-cathode potential, the deviation is a function of the applied voltage as well as of the frequency.

Figure 4 shows the ratio of applied voltage to indicated voltage for the TYPE 726-A Vacuum-Tube Voltmeter as a function of frequency, for several different voltage levels. These data were taken with the plug tips of the voltmeter probe removed. If the tips are in place and the voltage is applied near the ends, the deviation is larger than that indicated, since the resonant frequency is lowered by the added inductance and capacitance of the tips.

It will be observed that, at the high voltage levels, the percentage deviation is essentially independent of voltage. That is, the electron transit time is small by virtue of the relatively high accelerating field acting, and resonance is the controlling factor in the behavior. At lower levels, however, the transit time phenomenon introduces a compensating effect which reduces the deviation between the true value and the indicated value of voltage. At levels in the vicinity

FIGURE 4. Plot of the ratio of applied voltage to indicated voltage as a function of frequency for several different levels of indicated voltage. The voltage levels are indicated by the figures associated with each curve.

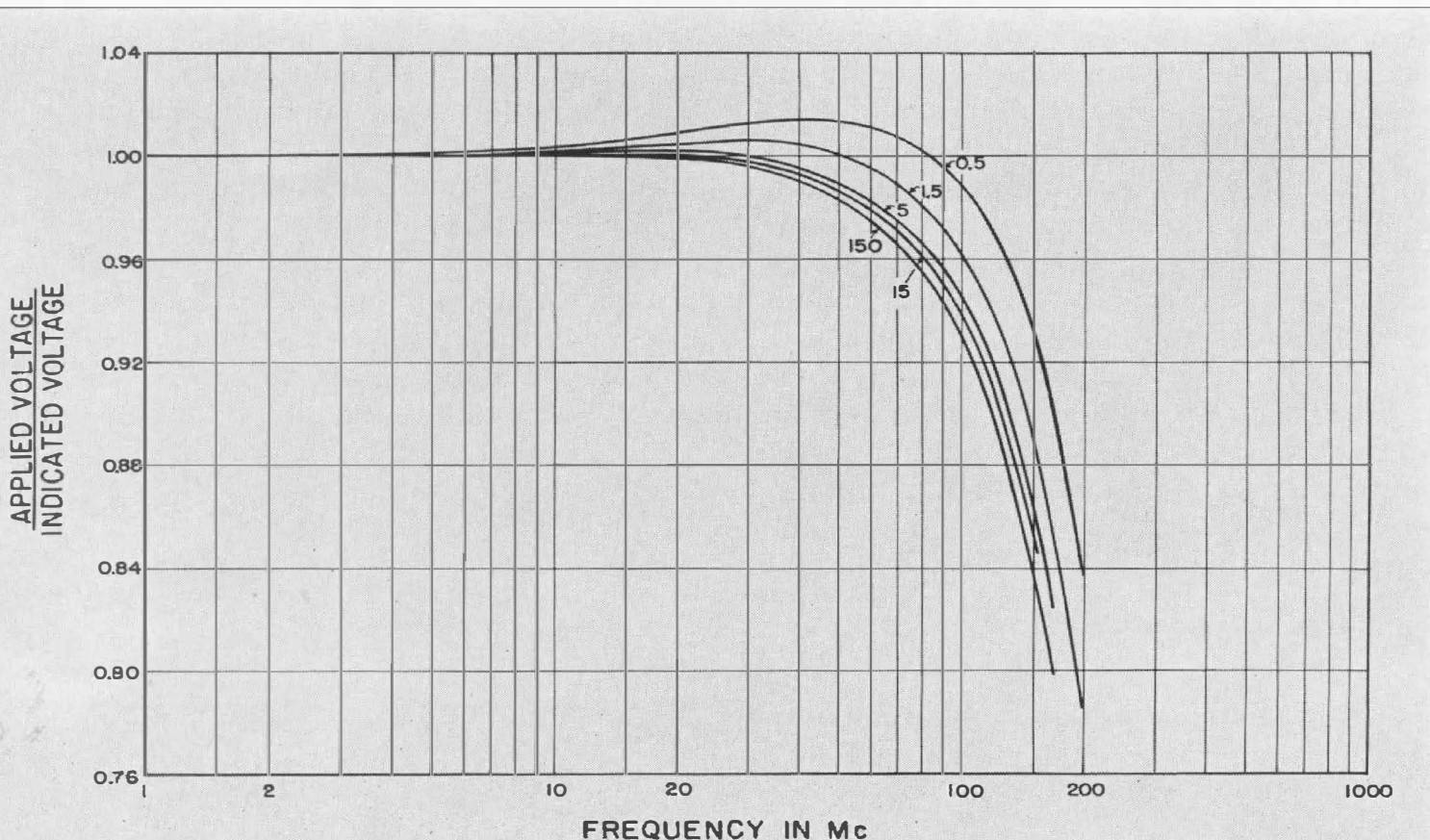

of $\frac{1}{2}$ volt the two effects very nearly cancel each other, and the frequency error is less than 2% up to 100 megacycles. At frequencies up to about 50 megacycles the frequency error is less than $\pm 2\%$ for all levels.

The curves of Figure 4 also apply when the TYPE 726-P1 Multiplier is used, since it introduces no appreciable frequency error in the range from 1 to 100 megacycles.

When non-sinusoidal voltages are being measured at high frequencies, the peak value of the voltage acting on the diode may be markedly different from the peak value at the probe terminals,

because of the different value of resonant rise experienced by the various components of the voltage. Consequently, considerable caution must be exercised in interpreting readings at the higher frequencies, if the voltage under measurement is not very nearly sinusoidal. For sinusoidal voltages, however, it is possible to make measurements at frequencies up to 150 megacycles with substantially the same accuracy that obtains at lower frequencies, by using the correction factors indicated in Figure 4.

— IVAN G. EASTON

REFERENCES

¹W. N. Tuttle, "TYPE 726-A Vacuum-Tube Voltmeter" — *General Radio Experimenter*, Vol. XI, No. 12, May, 1937.

²D. B. Sinclair, "The TYPE 726-A Vacuum-Tube Voltmeter as a Radio-Frequency Ammeter" — *General Radio Experimenter*, Vol. XIII, Nos. 3 and 4, August-September, 1938.

³D. B. Sinclair, "A Voltage Multiplier for Use With the Vacuum-Tube Voltmeter at Radio Frequencies" — *General Radio Experimenter*, Vol. XIV, No. 12, May, 1940.

⁴L. S. Nergaard, "Electrical Measurements at Wave Lengths Less Than Two Meters" — *Proc. I.R.E.*, Vol. 24, No. 9, p. 1207, September, 1936.

⁵E. C. S. Megaw, "Voltage Measurements at Very High Frequencies" — *Wireless Engineer*,

Vol. XIII, No. 149, p. 65, Vol. XIII, No. 150, p. 135, and Vol. XIII, No. 151, p. 201.

⁶C. L. Fortescue, "Thermionic Peak Voltmeters for Use at Very High Frequencies" — *Proceedings of Wireless Section, I.E.E.*, Vol. X, No. 262, 1935.

⁷C. B. Aiken, "Theory of the Diode Voltmeter" — *Proc. I.R.E.*, Vol. 26, No. 7, p. 859, July, 1938.

⁸D. B. Sinclair, "A New Null Instrument for Measuring High-Frequency Impedance" — *General Radio Experimenter*, Vol. XV, No. 7, January, 1941.

⁹R. F. Field, "An Improved Measuring Circuit for the Susceptance Variation Method" — *General Radio Experimenter*, Vol. XV, No. 4, September-October, 1940.

● **LAST MONTH** we pointed out that, in order to conserve essential materials for National defense, substitutes are being used in General Radio instruments. An example of this is the use of plastics instead of aluminum for panels where the substitution does not impair the performance of the instrument. Important mechanical characteristics such as strength and stability, as well as appearance, have been considered in selecting the most acceptable substitute, so that the high standard of quality in General Radio instruments will be maintained.

Maintenance of quality is particularly important at this time, because the bulk of our products is going either to manufacturers and laboratories engaged in National defense work or directly to the various government activities.

THE GENERAL RADIO STANDARDIZING LABORATORY

● **QUALITY CONTROL IN INSTRUMENT MANUFACTURE** is an extremely important function. However well-designed an instrument may be, accurate calibration and reliability in service are the qualities that determine its ultimate usefulness. Careful inspection, adjustment, and standardization are necessary to achieve the reliability and accuracy that are promised in the manufacturer's published specifications.

At the General Radio Company, the Standardizing Laboratory is the final link between the Company and the customer. Any errors or defects that may have occurred in manufacture must be caught and corrected in this laboratory. Instruments are then adjusted for optimum performance and calibrations are made. Obviously, the laboratory's job must be well done or customer dissatisfaction is bound to result.

The principal function of the Standardizing Laboratory is the performance of standard engineering-test and calibration operations as a routine produc-

tion procedure. Closely allied to this are the inspection and test of component parts before their assembly into complete instruments. The complete production of piezo-electric quartz crystals is also carried on as an activity of the laboratory, since the preparation of these is primarily a precision calibration operation involving adjustments in terms of a known standard.

Capable personnel, adequate test equipment, and standardized test procedure are essential if a uniformly accurate and reliable product is to be turned out. Of the twenty men who test General Radio instruments, six have engineering degrees and ten others are graduates of engineering institutions. In addition to permanent laboratory personnel, the staff usually includes several students pursuing co-operative courses in electrical engineering at nearby engineering schools and colleges.

Some \$25,000 worth of standard General Radio instruments are permanent equipment in the laboratory, including 3 Wave Analyzers, 6 Beat-Frequency

FIGURE 1. View of a portion of the Standardizing Laboratory, showing a group of TYPE 605 Standard-Signal Generators undergoing test and calibration.

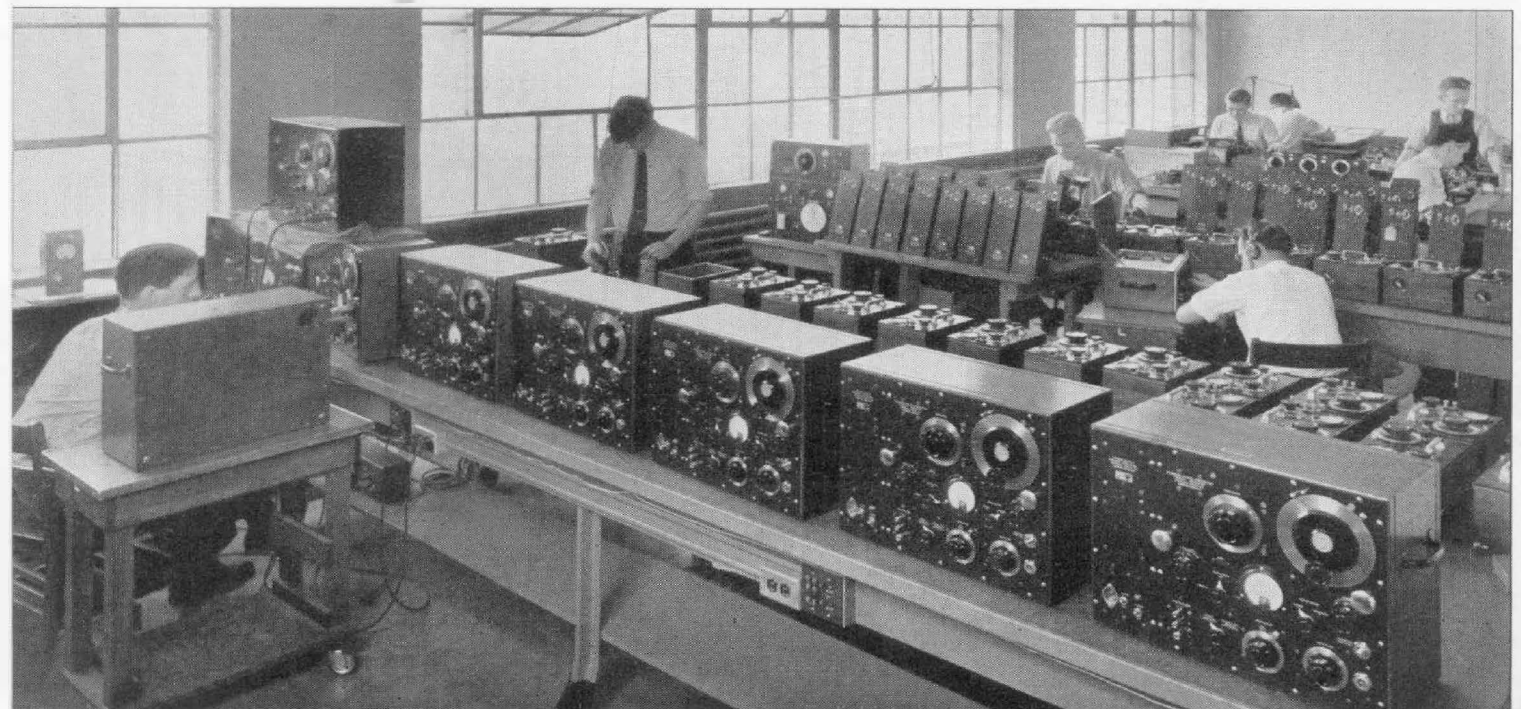

Oscillators, 6 Vacuum-Tube Voltmeters, 7 Bridges, 8 Heterodyne-Frequency Meters, and at least one each of most other instruments in the General Radio catalog; and there are, of course, many special instruments and assemblies designed to meet specific test requirements.

Definitely prescribed test schedules are carried out on each instrument. The tests to be made are specified by the engineer responsible for the development of the instrument, and the detailed testing specifications are worked out jointly by the engineer in charge of testing and the development engineer.

The thoroughness of the test procedure followed on most instruments can be illustrated by listing the tests performed on a TYPE 736-A Wave Analyzer. In brief, these consist of

1. Over-all Inspection of Mechanical Assembly.
2. Input Power Measurement.
3. Adjustment of Plate Supply Voltage.
4. Adjustment of Oscillator Range.
5. Balance Adjustments on Detector.
6. Preliminary Adjustment of Crystal Filter to Obtain Desired Band-Pass Characteristics.
7. Detector Tuning Adjustment.
8. Final Crystal Filter Adjustments.
9. Over-all Gain Measurement.
10. Detector Distortion Measurement.
11. Attenuator Check.
12. Meter Check.
13. Input Multiplier Check.
14. Phase Inverter Linearity Test.
15. Frequency Response Measurement.
16. Absolute Voltage Calibration.
17. Hum Measurement.
18. Frequency Calibration.

These instruments are tested in groups of five, that is, each test is performed on each instrument of the group before the test man proceeds to the next



FIGURE 2. Calibrating a TYPE 722 Precision Condenser in the Standardizing Laboratory.

test. In this way, more efficient use of time and equipment is possible than when the complete test schedule is performed on each instrument in turn. Yet the minimum test time per instrument is about six man hours, when no difficulties that require trouble shooting are encountered.

The activities of the Standardizing Laboratory, however, are not confined to production alone, but also touch engineering, sales, and service.

The engineering functions of the laboratory are threefold, embracing the determination of performance data on new instruments, the maintenance of standards, and the training of engineering assistants for the development engineering group.

Trial production lots of new instruments (usually numbering either five or ten units) are given particularly comprehensive tests. Over-all performance tests are made to determine catalog specifications; errors and omissions in manufac-

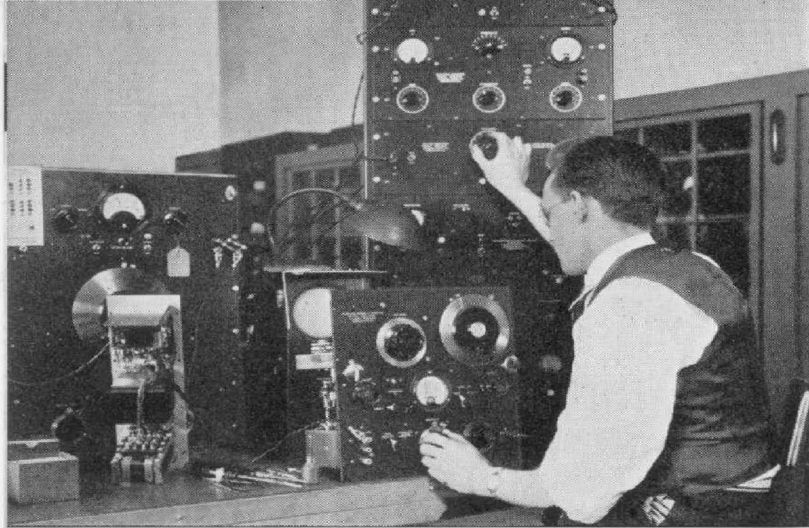

FIGURE 3. Modulation tests on a TYPE 605 Standard-Signal Generator.

turing specifications are corrected; and, finally, operating tests under severe temperature and humidity conditions are made.

In order to calibrate instruments for voltage, resistance, capacitance, inductance, and frequency, accurate standards are necessary. These are maintained in the laboratory with the exception of the Primary Standard of Frequency, which is located in the Engineering Department. All working standards of resistance, inductance, and capacitance are intercompared periodically, and several are sent yearly to the U. S. Bureau of Standards for recalibration.

Testing specifications allow in general about three-quarters of the tolerance given in the catalog specifications. That is, a resistor with a published accuracy

of 0.1% is rejected by the laboratory if its error is over 0.075%.

The Standardizing Laboratory provides excellent training for engineering assistants, and, from time to time, laboratory personnel are assigned to the development engineering group for work under the supervision of development engineers.

Not so obvious, but extremely important is the laboratory's connection with sales. It is the responsibility of the laboratory administration to control inventories so that no more than four months' supply of major instruments is kept in the stockroom. This policy has two beneficial results. It permits laboratory time to be allotted most efficiently in terms of salable instruments, and it assures the customer that the calibration of any instrument that he purchases is no more than four months old. Some particularly critical calibrations, however, are made only upon receipt of a customer's order.

Each repaired instrument is completely tested and calibrated to the same specifications as a new instrument of the same type. Since the volume of repairs cannot be easily controlled, close cooperation between the laboratory and the Service Department is essential in order to avoid delays in returning repaired instruments to their owners.

GENERAL RADIO COMPANY

30 STATE STREET - CAMBRIDGE A, MASSACHUSETTS

BRANCH ENGINEERING OFFICES

90 WEST STREET, NEW YORK CITY

1000 NORTH SEWARD STREET, LOS ANGELES, CALIFORNIA